

©1969 BY AMP INCORPORATED. ALL RIGHTS RESERVED. AMP PRODUCTS COVERED BY PATENTS AND/OR PATENTS PENDING.

THIS PRODUCT DESIGNED AND BUILT BY AMP INCORPORATED. NO LICENSE TO USE THAT DESIGN IN MANUFACTURE, OR TO USE ANY ISSUED OR PENDING PATENTS WHICH ARE INVOLVED, IS IMPLIED.

REVISIONS				
ZONE	LTR	DESCRIPTION	DATE	APPROVED
	A	REV. POSITION OF Δ DIM (ECN 416A)	12/18/73	RE JMY
	B	REV. PER E.C.N 8678	AG 3-1-79	M. J.
	C	OBS-RECND F 6376	2/2-89	T.W.
	D	REV PER OH4-0192-05	1-06	PY

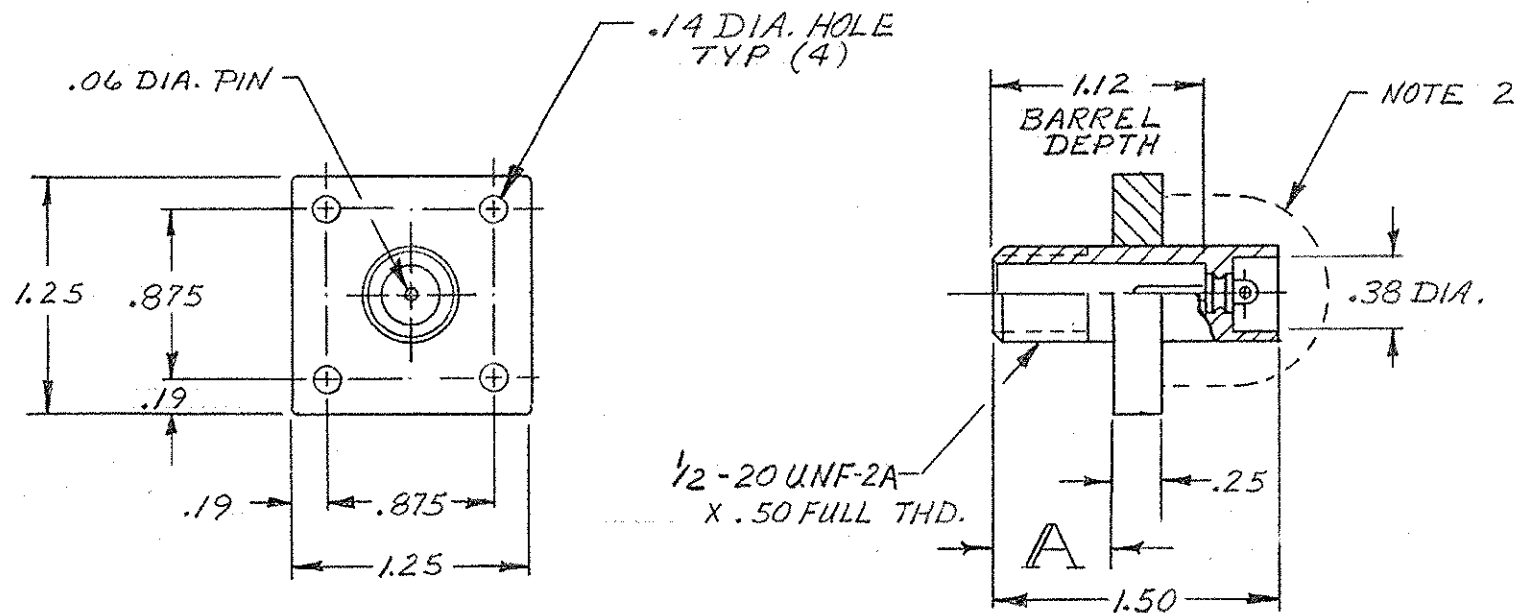

NOTE:

1. RECEPTACLE TO MATE WITH AMP LGH-1 LEAD ASSEMBLY, AVAILABLE SEPARATELY.

2. CUSTOMER MUST PROTECT THE RECEPTACLES BACK END AGAINST ARC OVER & BREAKDOWN.

PART NO.	"A"	TERMINAL PLATING			OBSOLETE
		TIN-LEAD	GOLD	TIN	
849611-1	.63	X			
849611-2	.63		X		
5-849611-1	.63			X	

ITEM NO.	DWG SIZE	PART OR IDENTIFYING NO.	NOMENCLATURE OR DESCRIPTION	SYMBOL
----------	----------	-------------------------	-----------------------------	--------

UNLESS OTHERWISE SPECIFIED: DIMENSIONS ARE IN INCHES TOLERANCES .00 ± .04 ANGLES = .000 ± .015				CONTRACT NO. DR <i>L. Hill</i> 4-17-69		AMP INCORPORATED CAPITRON DIVISION ELIZABETHTOWN, PENNSYLVANIA		
MATERIAL: GLASS EPOXY MOLDED				APPD <i>E. Johnson</i> 4/18/69				NAME LGH-1 FLANGED RECEPTACLE (FOR BULKHEAD APPLICATION)
FINISH: BLACK				DSGN APPD		SIZE B	CODE IDENT NO.	NUMBER 849611
NEXT ASSY		FINAL ASSY		OTHER APPD		SCALE	WT	SHEET 1 OF 1
QTY REQD		APPLICATION						

PRINT DIST 50 DF